

SELF-CONTAINED LUMINAIRE

DMJ B



sermat **GRÜN**
ex

REV.11 / 28.04.2026

SELF-CONTAINED LUMINAIRE - DMJ B

Technical data

SPECIFICATIONS

TYPE OF PROTECTION	Ex "e" - increased security Ex "m" - encapsulated Ex "q" - immersed in sand Ex "op is" - inherently safe optic radiation Ex "t" - dust ignition protection
MARKING	Ex eb mb q op is IIC T6 Gb (luminárias com outras potências) Ex tb op is IIIC T77°C Db (luminárias com outras potências).
AREA OF APPLICATION	Zone 1 Zone 2 Zone 21 Zone 22
INGRESS PROTECTION	IP66W (W: Salt Spray)
OPERATING TEMPERATURE (ENVIRONMENT)	40°C to +50°C (-40°F to 122°F)
CABLES ENTRY/EXIT	4 cable entries/exits, equipped with 1 to 4 M20x1.5 or M25x1.5 cable glands. M25x1.5 cable gland for cables with a diameter of 10 mm to 17 mm. M20x1.5 cable gland for cables with Ø 7 mm to Ø 13 mm.
OPERATING VOLTAGE RANGE	108 / 254 Vac/cc 50 / 60 Hz
CURRENT	max. 570 mA
POWER	10 W
LUMINOUS FLUX	± 1040 lm
LAMP	LED
WEIGHT	4,0 kg
AUTONOMY TIME (EMERGENCY)	180min
CRI	80
VERSÕES	Bloco Autônomo (DMJ B...)
VIBRATION RESISTANCE	According to ABNT NBR IEC 60598-1
COLOR TEMPERATURE (TCC)	5700 K
SIZE	P: 373mm

CERTIFICATIONS

Segurança



OCF 0034



INMETRO

INMETRO

NCC 24.0139 X

SELF-CONTAINED LUMINAIRE - DMJ B

Technical data

DIMENSIONS (MM)

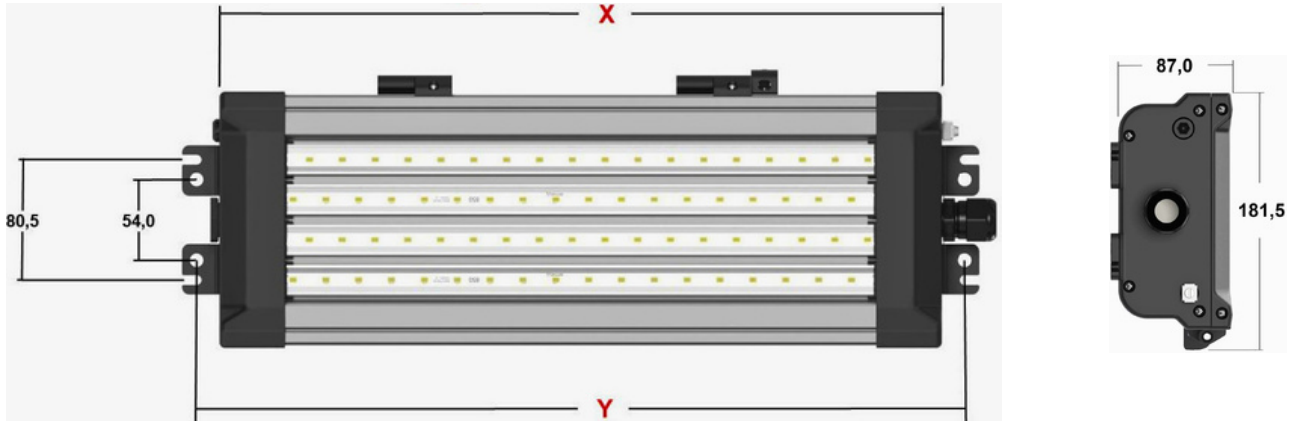

X	Y
373 mm	403 mm

ORDERING CODE

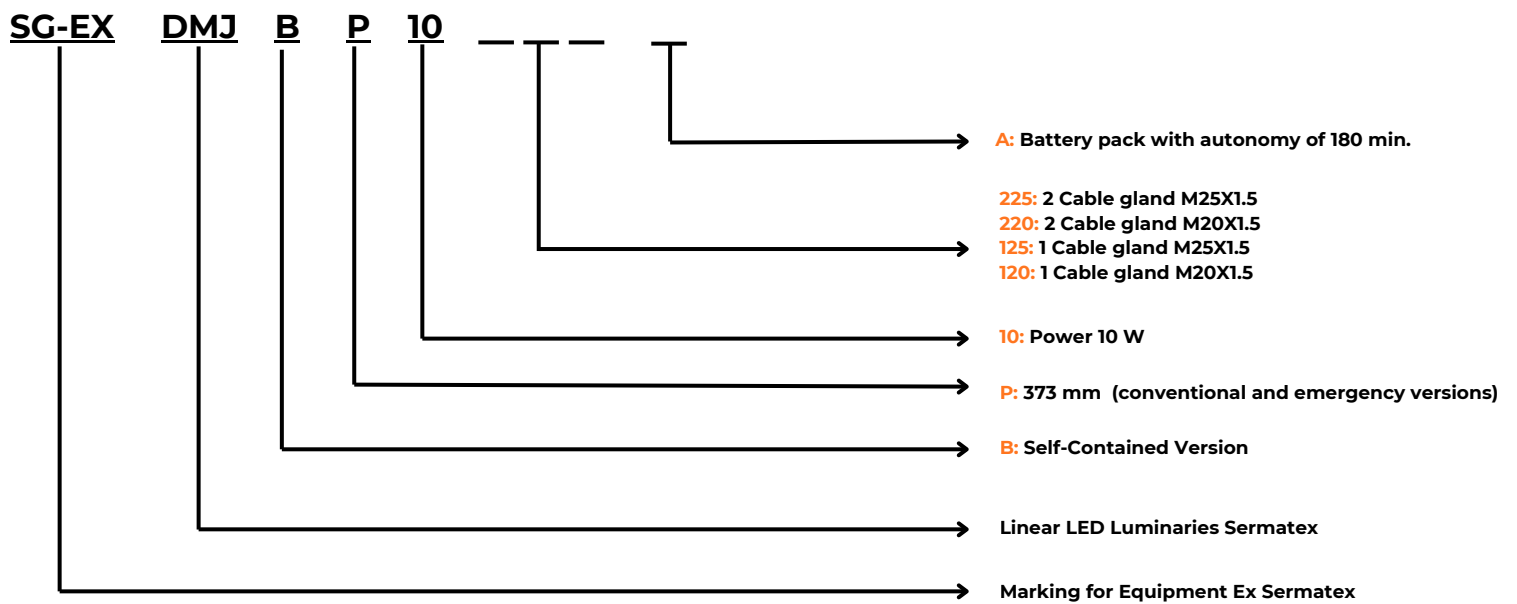

NOTE:
Cable gland M25X1.5 for cables with \varnothing 10 to \varnothing 17 mm.
Cable gland M20X1.5 for cables with \varnothing 7 to \varnothing 13 mm.

SELF-CONTAINED LUMINAIRE - DMJ B

Technical data

Highlights

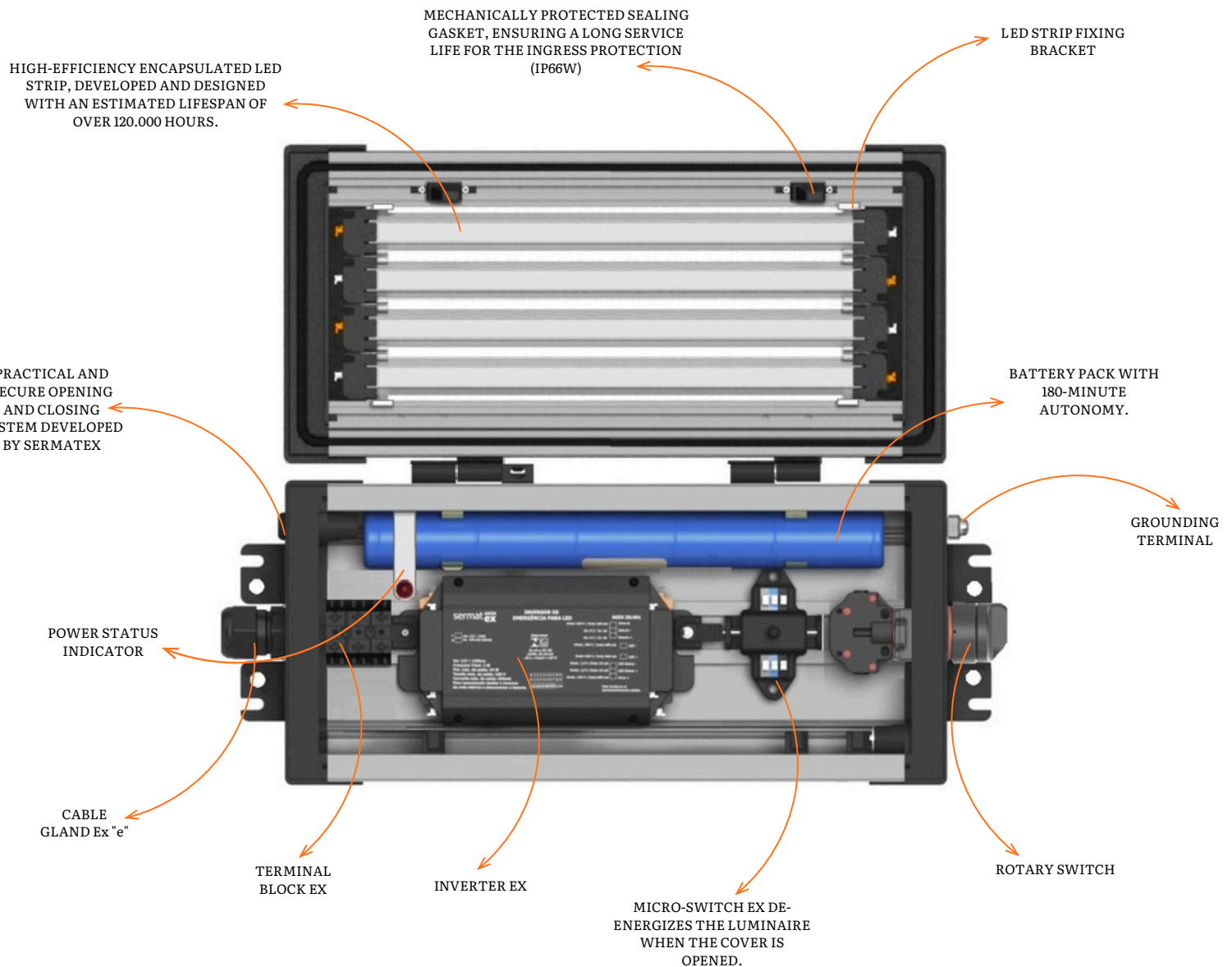

SELF-CONTAINED LUMINAIRE - DMJ B

Technical data

ELECTRICAL SCHEME

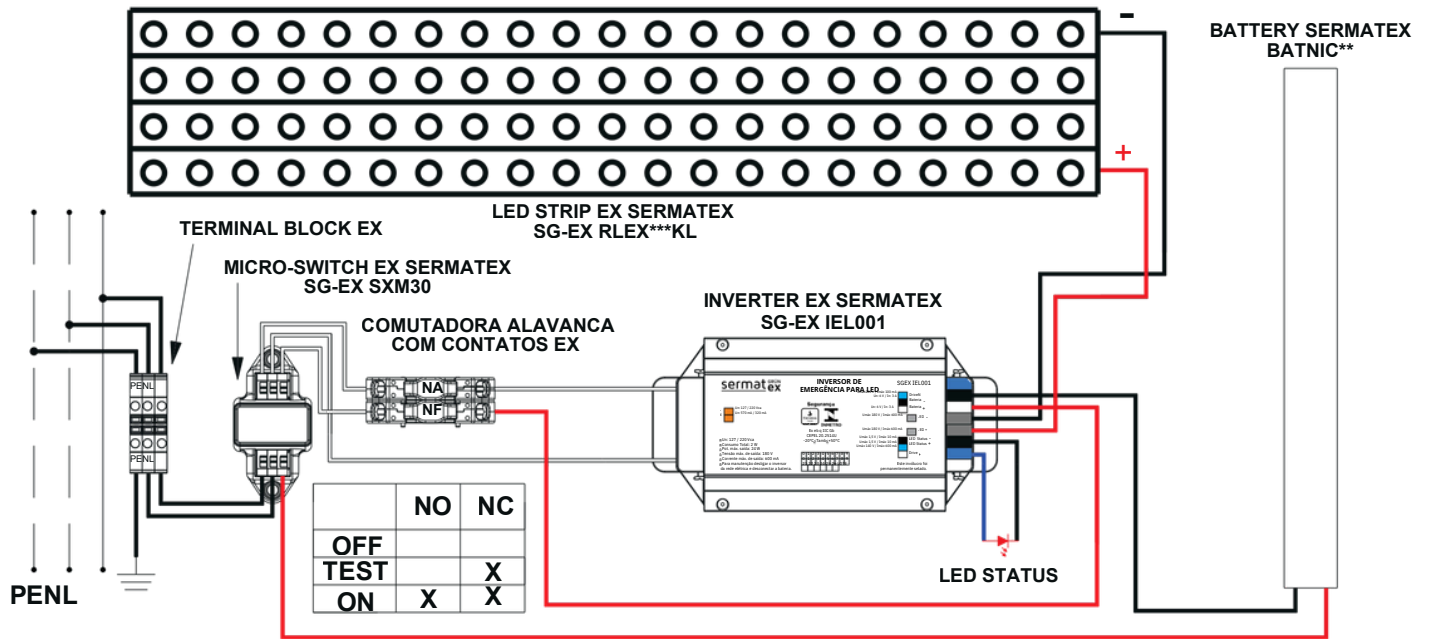

REPLACEMENT PARTS



Code: SG-EX IEL001
Description: Inverter Ex 70 W



Code: SG-EX SXM30
Description: Micro-Switch Ex 3 NA



Code: BATNIC03
Description: Battery Pack Auton. 180 min.



Código: SG-EX22GCAGC1A10EX
Descrição: Rotary Switch ON/OFF Positions (1 NO)



Code: TDMJBP10
Description: Self-Contained Luminaire Cover with 10 W LED Strip Ex

SELF-CONTAINED LUMINAIRE - DMJ B

Technical data

FIXATION BRACKET

BRACKET WITH ADJUSTABLE TILTING FOR WALL FIXING

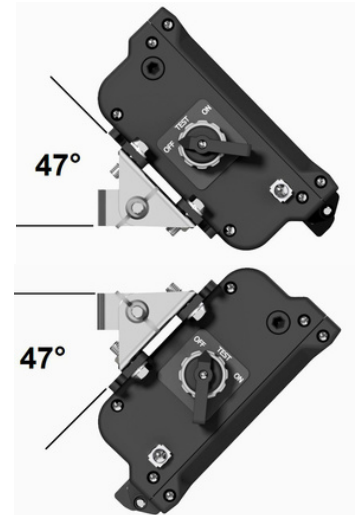
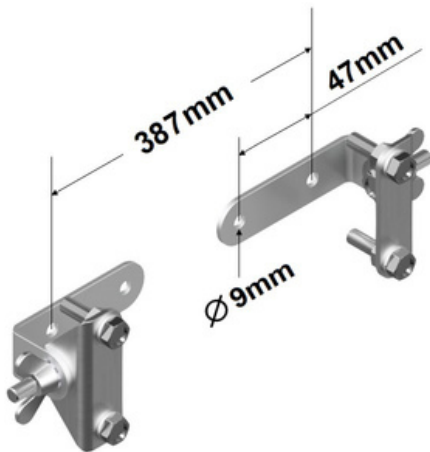

Code: SUPDMJBAFPA

PORTABLE FLOOR STAND WITH CARRY HANDLE



Code: SUPDMJBAPAP